

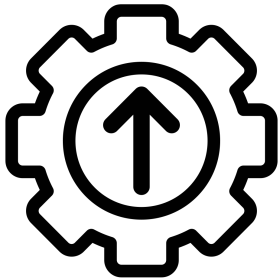

CLICK PART NUMBERS TO ORDER



GET ***INTERACTIVE*** MANUAL

AVAILABLE AIR ASSIST AIRLESS ORIFICES

PART NO.	ORIFICE SIZE	SPRAY ANGLE (DEGREES)	APPROX. PATTERN SIZE	PART NO.	ORIFICE SIZE	SPRAY ANGLE (DEGREES)	APPROX. PATTERN SIZE
36-207	0.007	20	4"	36-315	0.015	30	6"
36-309	0.009	30	6"	36-415	0.015	40	8"
36-409	0.009	40	8"	36-515	0.015	50	10"
36-311	0.011	30	6"	36-615	0.015	60	12"
36-411	0.011	40	8"	36-715	0.015	70	14"
36-511	0.011	50	10"	36-815	0.015	80	16"
36-213	0.013	20	4"	36-417	0.017	40	8"
36-313	0.013	30	6"	36-517	0.017	50	10"
36-413	0.013	40	8"	36-619	0.019	60	12"
36-513	0.013	50	10"	36-621	0.021	60	12"
36-613	0.013	60	12"				

Operation and Maintenance Instructions for *Bobcat* Spray Guns

Operation

1. Connect air supply hose at handle of gun.
2. Connect material supply hose from pump to the gun fluid inlet.
3. The trigger safety is activated when trigger is pushed forward.
4. Maximum pattern width is determined by tip selection. Turning the fan control knob counter clockwise will narrow the fan. Pattern is maximum when fan control is completely closed.
5. For HVLP compliance, do not exceed 18 psi air pressure at gun handle.

MAINTENANCE NOTE:

- **Complete gun disassembly is not recommended for normal cleaning and maintenance.**
- **Not recommended to soak entire spray gun in solvent.**

IMPORTANT! Relieve gun fluid pressure to 0 psi before performing any maintenance.

10-137 Gun Repair Kit (soft seals only)

10-138 Complete Gun Repair Kit

Replacing needle cartridge assembly

1. Remove the trigger by removing both trigger screws (28).
2. Remove fluid spring cap (22) using a 3/8" wrench.
3. Remove needle return spring (21) and push rod (20).
4. Remove air valve assembly (19) using a 9/16" wrench.
5. Using a 3/8" wrench remove the needle seal body (27). The needle seal cartridge (27) can be removed through the back of the gun.
6. Inspect o-rings (16) and (17) and replace if necessary.

Replacing gun seat

1. Remove air cap (2) and tip (3). Using 1/2" socket, remove fluid nozzle body (7).
2. Using an 1/8" rod, push both the seat (8) and seat retainer (9) out of the nozzle body.

Replacing gun filter

1. Using a 3/4" open end wrench, remove filter retainer nut (31) and separate the upper and lower filter housings exposing the filter. It is not necessary to disconnect the fluid hose to change the filter. NOTE: The gun is equipped with a 100 mesh filter as standard. 60 mesh filters are also available.

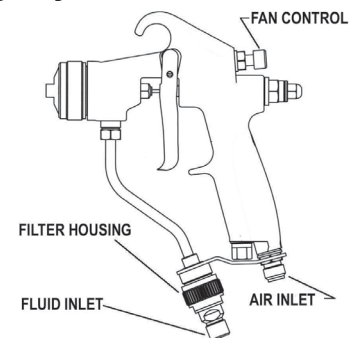

CET

DISTRIBUTED BY COATING EQUIPMENT TECHNOLOGY, INC

PHONE: 586-210-0555

WEB: www.cetinc.com

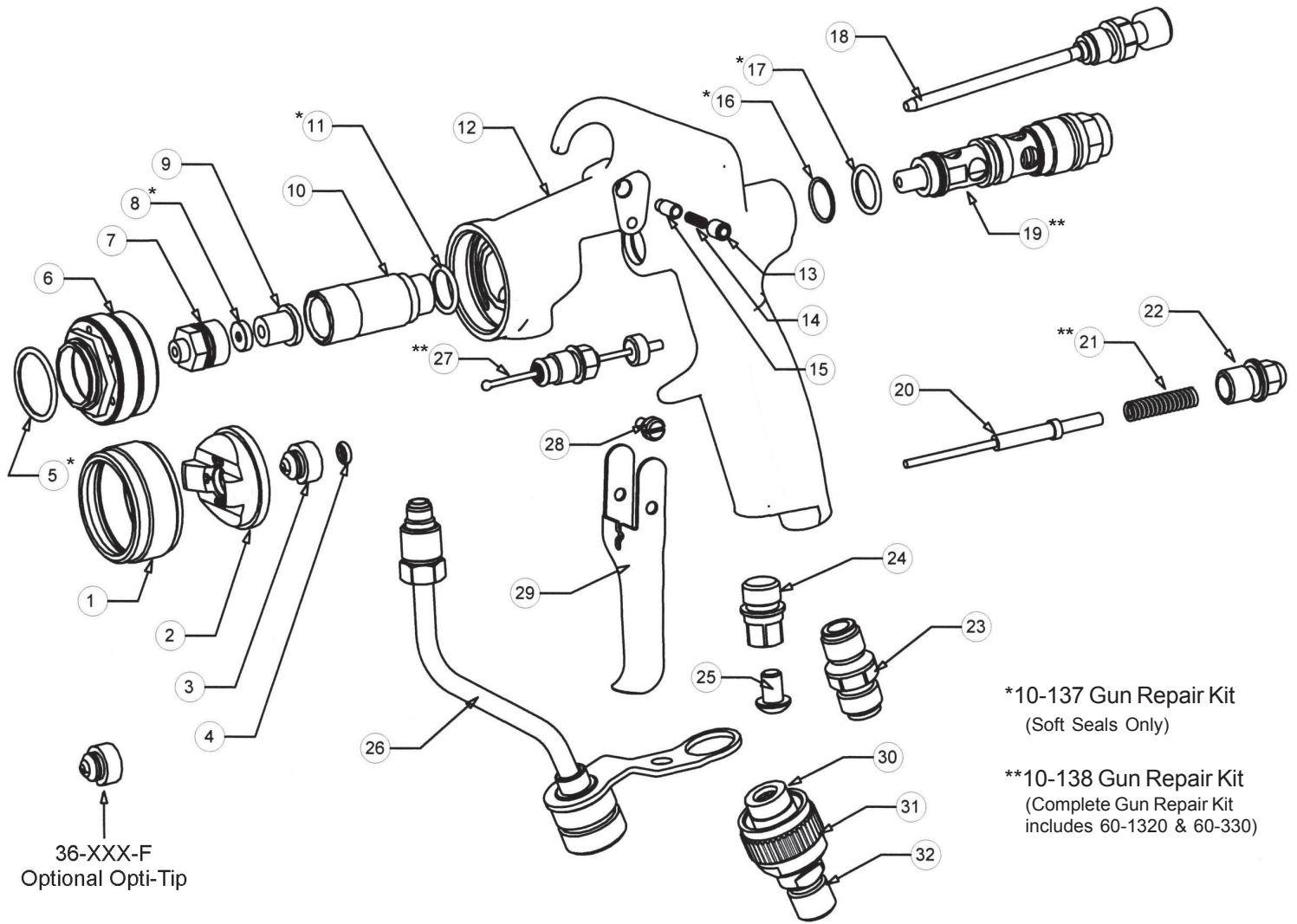

CLICK PART NUMBERS TO ORDER ONLINE

ITEM NO.	PART NO.	DESCRIPTION	ITEM NO.	PART NO.	DESCRIPTION
1	21-1001	Air Cap Ring	19	60-1320	Air Valve Assembly**
2	26-101	Air Cap	20	66-337	Push Rod
3	36-XXX	Fluid Tip	21	66-344	Spring
4	98-8007	O-Ring*	22	66-340	Spring Cap
	36-100	Tip Strainer (optional)	23	60-104	Air Inlet Fitting
5	98-8019	O-Ring*	24	66-319	Handle Plug
6	66-103	Air Cap Adapter	25	98-0186	Screw
7	66-104	Nozzle Body	26	66-315	Fluid Tube Assembly
8	66-105	Seat*	27	66-330	Needle Seal Cartridge**
9	66-110	Seat Retainer	28	60-1315	Trigger Pivot Screw
10	66-302	Nozzle Carrier	29	66-350	Trigger
11	98-8014	O-Ring*	30	66-125	Filter (100 mesh standard)
12	66-301	Gun Body		66-124	Filter (60 mesh optional)
13	98-0275	Set Screw	31	66-123	Filter Retaining Nut
14	66-310	Spring	32	66-122	Filter Housing, Lower
15	66-313	Pin, Trigger Safety	Repair Kits		
16	98-5125	O-Ring*	10-137	Gun Repair Kit (soft seals only)	
17	98-5225	O-Ring*	10-138	Complete Gun Repair Kit	
18	66-308	Fan Control			

Bobcat Gun Air Consumption

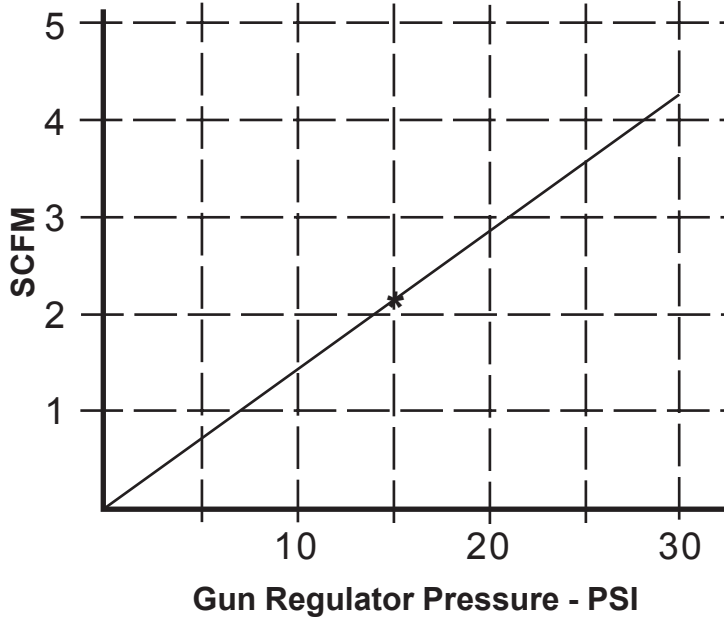

*Max pressure for HVLP

B14 AAA Pump Air Consumption

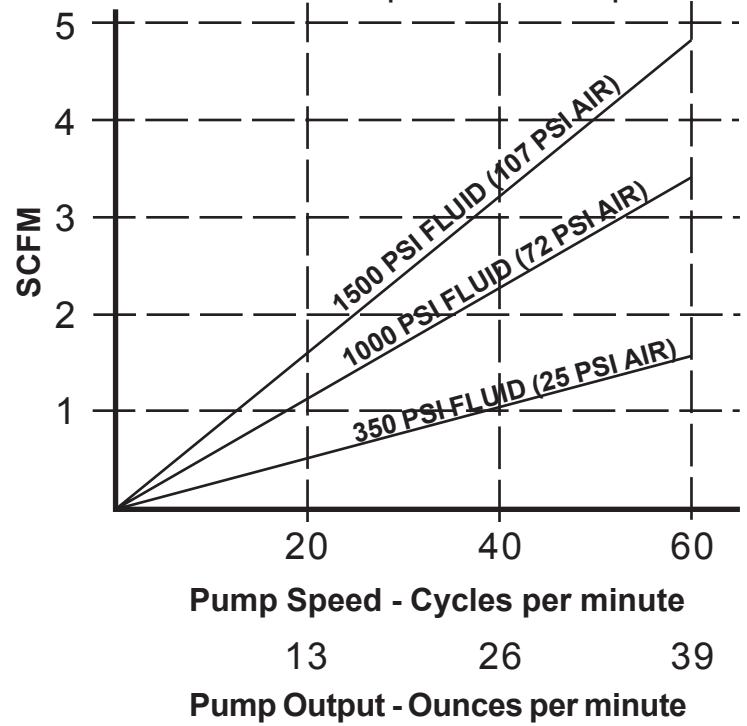

Pump Output - Ounces per minute
13 26 39

Compressed Air Requirements

Minimum compressor size will vary with the application. Air requirements for the gun and pump must be added together for total air requirements.

Example: Gun Regulator Setting 25 psi, scfm = 3.5
 Pump fluid pressure is 1000 psi and cycle rate is 30, scfm = 1.75
 Minimum compressor requirement: 3.5+1.75 = 5.25 scfm

Fluid Tip Flow Rate Chart (Fluid oz/min.)

Tip Size	Pressure (psig)							
	350		700		1000		1500	
	Light Materials	Heavy Materials	Light Materials	Heavy Materials	Light Materials	Heavy Materials	Light Materials	Heavy Materials
0.007	3	---	4	---	5	---	6	---
0.009	5	---	8	---	9	---	11	---
0.011	8	---	11	---	13	---	16	---
0.013	10	---	14	---	17	---	21	---
0.015	13	---	18	---	22	---	27	---
0.017	17	13	24	18	29	22	35	27
0.019	21	16	30	23	36	27	44	33
0.021	27	21	38	29	45	35	56	43

Note: Values are approximate and will vary depending on actual material viscosity.